

# DUMPSBOSS.

**Specialist - Platform Engineer PowerStore Exam**

**EMC DES-1241**

**Version Demo**

**Total Demo Questions: 10**

**Total Premium Questions: 98**

**Buy Premium PDF**

**<https://dumpsboss.co>**

**[support@dumpsboss.co](mailto:support@dumpsboss.co)**

**support@dumpsboss.co**  
**dumpsboss.co**

## QUESTION NO: 1

Which number in the code-naming schema represents a beta distribution?

- A. 8
- B. 6
- C. 4
- D. 5

ANSWER: C

## QUESTION NO: 2 - (DRAG DROP)

DRAG DROP

Correctly order the steps of the embedded module replacement procedure.

Select and Place:

Push the orange tab to release the lever of the embedded module	Step 1
Power down the node	Step 2
Label and disconnect all cables attached to the embedded module	Step 3
Align the embedded module with the empty slot and carefully push it into the slot	Step 4
Remove the 4-port card from the old embedded module and install it into the new embedded module	Step 5

ANSWER:

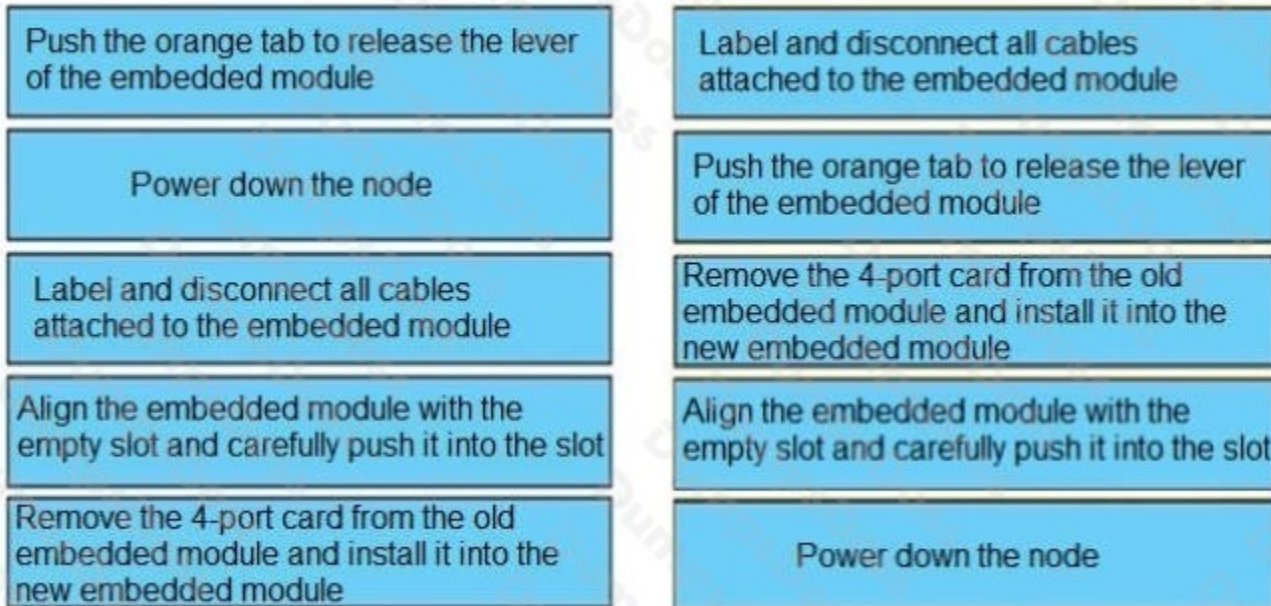

**Explanation:**

Reference:

[https://topics-cdn.dell.com/pdf/pwrstr-isg\\_en-us.pdf](https://topics-cdn.dell.com/pdf/pwrstr-isg_en-us.pdf)

### QUESTION NO: 3

What method is used to power down a Dell EMC PowerStore system in a true emergency situation?

- A. Run `svc_node shutdown`
- B. Power Down Cluster in PowerStore GUI
- C. Turn off the cabinet switches
- D. Remove base enclosure power cables

### ANSWER: C

**Explanation:**

Reference: <https://www.dell.com/support/manuals/pk/en/pkbsd1/powerstore-1000/pwrstr-isg/power-control-procedure-considerations?guid=guid-4352c94e-0ae7-4a2e-8593-9ae135bb9e34&lang=en-us>

### QUESTION NO: 4

What is the result of setting a VLAN ID of 0 on a network when running ICW for Dell EMC PowerStore?

- A. Network will pass tagged traffic

- B. Static route is set
- C. Network will pass untagged traffic
- D. Default route is set

**ANSWER: C**

**Explanation:**

Reference: [https://topics-cdn.dell.com/pdf/pwrstr-ntwk-plang\\_en-us.pdf](https://topics-cdn.dell.com/pdf/pwrstr-ntwk-plang_en-us.pdf) (22)

## QUESTION NO: 5

What describes the SAS cabling when adding an expansion enclosure to a Dell EMC PowerStore, for each node and expansion enclosure side?

- A. SAS cabling goes from existing A ports to new B ports. At the last enclosure, SAS cabling returns from the A ports to the originating node's B ports
- B. SAS cabling goes from existing A ports to new B ports. At the last enclosure, SAS cabling returns from the A ports to the alternate node's B ports
- C. SAS cabling goes from existing B ports to new A ports. At the last enclosure, SAS cabling returns from the B ports to the alternate node's A ports
- D. SAS cabling goes from existing B ports to new A ports. At the last enclosure, SAS cabling returns from the B ports to the originating node's A ports

**ANSWER: B**

## QUESTION NO: 6

While on-site troubleshooting a Dell EMC PowerStore system, the node B embedded module fault LED is blinking blue and amber alternating at one second intervals. What does this indicate?

- A. Node is in degraded mode
- B. Node is booting
- C. Node is on service mode
- D. System is not initialized

**ANSWER: C**

**Explanation:**

Blue and amber  
alternating at one second intervals

Node in Service Mode.

Reference: <https://www.dell.com/support/manuals/en-pk/powerstore-9000/pwrstr-isg/embedded-module-leds?guid=guid-bc07892c-75cf-43b6-8f17-8a4c49001aeb&lang=en-us>

### QUESTION NO: 7

What is a step in configuring the ToR data switches for a Dell EMC PowerStore T?

- A. Configure a port for the discovery laptop
- B. Create VLANs for NAS servers
- C. Create VLAN for vMotion networks
- D. Configure ports for management on native VLAN

ANSWER: D

### QUESTION NO: 8

Refer to the exhibit.



The screenshot shows the Dell EMC PowerStore management console. The top navigation bar includes 'Dell EMC PowerStore | TwoApplianceCluster' and various icons. Below the navigation bar, there are tabs for 'Dashboard', 'Monitoring', 'Compute', 'Storage', 'Protection', 'Migration', and 'Hardware'. The 'Hardware' tab is selected, and the 'APPLIANCES' sub-tab is active. A table lists two appliances:

Name	Alerts	Model	Mode	Service Tag	Express Ser...	Status	IP Address	Total
TwoApplianceCluster-appliance-1	--	PowerSt...	Unified	CBP42W2	2682869...	Online	192.168.1.31	
TwoApplianceCluster-appliance-2	--	PowerSt...	Block Op...	BBP42W2	24651914...	Online	192.168.1.42	

Which column indicates the master appliance?

- A. IP Address
- B. Model
- C. Service Tag
- D. Mode

**ANSWER: A**

## QUESTION NO: 9

Through which network do external hosts connect to the cluster for data access?

- A. Management
- B. ICM
- C. ICD
- D. Storage

**ANSWER: D**

### Explanation:

Reference: [https://topics-cdn.dell.com/pdf/pwrstr-hcg\\_en-us.pdf](https://topics-cdn.dell.com/pdf/pwrstr-hcg_en-us.pdf)

## QUESTION NO: 10

How is a service laptop IP configured to connect to the Service LAN port of a Dell EMC PowerStore node?

- A. Static IP: 128.221.1.249 and netmask: 255.255.255.0
- B. Obtain IP address from DHCP on PowerStore
- C. Static IP: 169.254.1.249 and netmask: 255.0.0.0
- D. Leave IP address and netmask unconfigured

**ANSWER: A**

### Explanation:

The service laptop being used to connect to the Service LAN Ports should be configured with:

- IP: 128.221.1.249
- Mask: 255.255.255.0

Reference: <https://www.dell.com/support/kbdoc/en-pk/000130356/powerstore-ssh-and-powerstore-manager-access-using-the-service-lan-ports>

## Usage

- For **ssh**, connect to the IPs shown above over port 22 using your preferred ssh client.
- For file transfers, SCP protocol must be used instead of SFTP/FTP (see [KB 000126621](#) for more info). The username for ssh is **service** and the password is the one setup during the initial configuration.  
**Attention:** if the system is not yet configured, that is, if the Initial Configuration Wizard (ICW) was not yet run, you may have to use port 26 instead. The username and password in this case are the pre ICW defaults.
- For the **PowerStore Manager (UI)**, use <https://128.221.1.250> or 251. UI access requires management services, which only runs on the primary node. If node A's IP doesn't work, try node B's IP address. The UI (PowerStore Manager) may not be accessible if management services or control path are not running or are experiencing issues.